



**STRONG PARTNERS.  
TOUGH TRUCKS.™**

# **P1.5UT**

## **ELECTRIC WALKIE PALLET TRUCK**

**[WWW.HYSTER.COM](http://WWW.HYSTER.COM)**

## > P1.5UT OVERVIEW

The Hyster® electric walkie pallet truck P1.5UT combines ergonomic features and reliable performance with energy efficient technology. Low maintenance delivers increased productivity and reduced operational costs.

### Productivity

- Small turning radius (1454 mm)
- Performs well on gradients
- Long handle reduces steering effort
- Drive capability when tiller is upright, greatly reduces turning space
- Entry roller for easy operation
- Variable speed control
- Built in charger
- Low speed switch in the handle
- Floating balance wheel automatically adjusts height and improves stability when unloading
- Emergency stop button
- Emergency reversing belly button
- Casters to increase stability

### Optimum Structural Design

- Formed heavy gauge steel provides maximum fork strength and longevity
- Pull rod design protects against bending
- Durable plastic covers
- Compact and lightweight design

### Serviceability

- Fast and efficient servicing
- Simple components
- Computer-based diagnostics not required
- Sealed maintenance-free batteries
- Tandem wheel option available

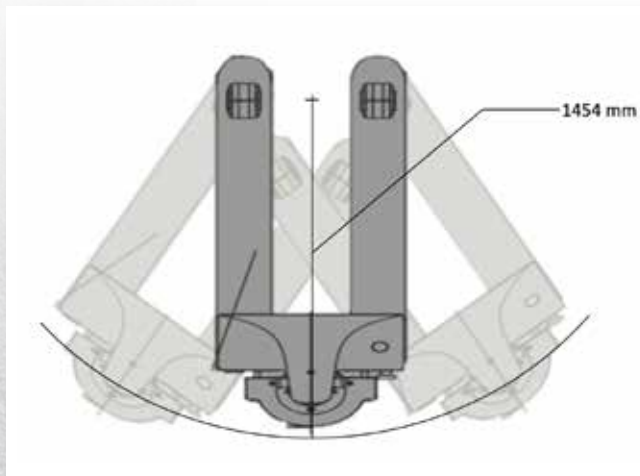

*Small turning radius*



*Handle (standard)  
(left and right  
handed)*



*Entry roller for  
easy operation*

## P1.5UT POWER PLUG TYPE



# SPECIFICATIONS AND DIMENSIONS

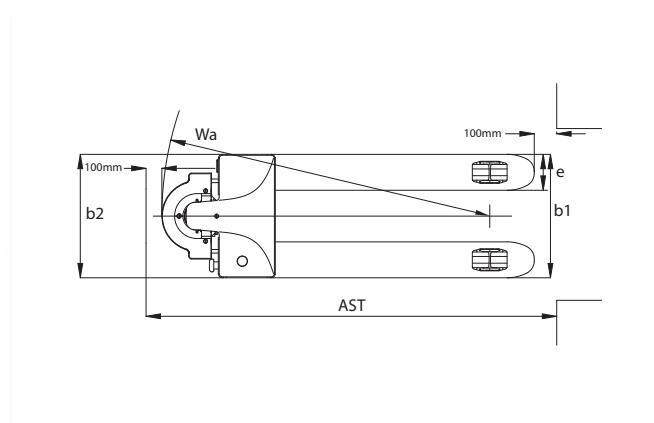
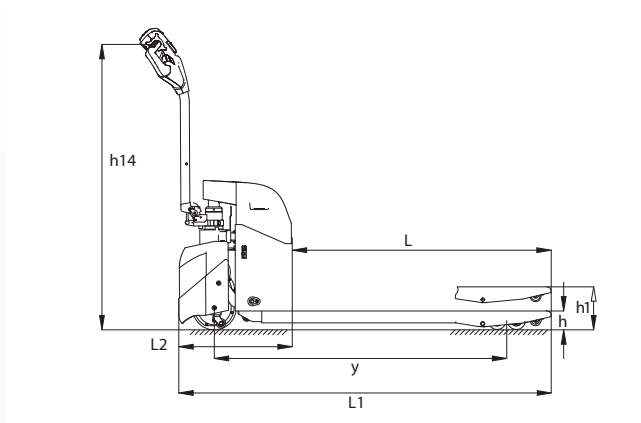

MODEL		P1.5UT
Power type		24-volt
Operator type		Pedestrian
Rated capacity	kg	1500
Load center	mm	600
Fork length	L (mm)	1150
Fork overall width	b1 (mm)	685 / 520
Fork width (individual fork)	e (mm)	160
Wheelbase (raised / lowered)	y (mm)	1287 / 1357
Overall length	L1 (mm)	1654
Outside turning radius (raised)	Wa (mm)	1454
Right angle stack (1000 x 1200 crossways)	AST (mm)	1854
Overall lift height – top of forks	h1 (mm)	190
Lowered height – top of forks	h (mm)	75
Total lift	mm	115
Truck overall width	b2 (mm)	685 / 562
Chassis length	L2 (mm)	504
Height of tiller (max)	h14 (mm)	1270
Battery compartment – standard	mm	228 / 138 / 214
Maximum gradeability (RL / NL)	%	5 / 10
Maximum travel speed (RL / NL)	kph	4.3 / 4.8
Traction motor control method type		DC
Service brake type		Electric
Truck weight (approximate) with battery - NL / RL	kg	205 / 1705
Drive tire – size / type (number of wheels)	mm	Φ195 x 70 Poly (1)
Load wheel – size / type (number of wheels)	mm	Φ74 x 90 Poly single / Φ74 x 70 Poly tandem
Battery type		Sealed
Battery ampere hours	Ah	65
Battery weight	kg	36
On-board charger	V	100-240

NL=no load  
RL=rated load



Hyster Company  
P.O. Box 7006  
Greenville, North Carolina  
27835-7006  
Part No. P1.5UT/BTG/LAM  
6/2020 Litho in U.S.A.

Visit us online at [www.hyster.com](http://www.hyster.com) or call us at **1-800-HYSTER-1**.

Hyster,  and STRONG PARTNERS, TOUGH TRUCKS, are registered trademarks in the United States and certain other jurisdictions. Hyster products are subject to change without notice.

Trucks may be shown with optional equipment. © 2020 Hyster Company. All rights reserved.